

Groundwater Research Report  
WRC GRR 97-04

**EFFECTS OF COMPLEX MIXTURES OF CHEMICALS IN LEACHATES  
ON THE TRANSPORT OF POLLUTANTS IN GROUNDWATER**

Timothy J. Grundl

1997

**EFFECTS OF COMPLEX MIXTURES OF CHEMICALS IN LEACHATES  
ON THE TRANSPORT OF POLLUTANTS IN GROUNDWATER**

Timothy J. Grundl  
Department of Geosciences  
University of Wisconsin-Milwaukee

Groundwater Research Report  
WRC GRR 97-04  
University of Wisconsin System  
Groundwater Research Program

Water Resources Center  
University of Wisconsin-Madison  
1975 Willow Drive  
Madison, Wisconsin

1997

*This project was supported, in part, by General Purpose Revenue funds of the State of Wisconsin to the University of Wisconsin System for the performance of research on groundwater quality and quantity. Selection of projects was conducted on a competitive basis through a joint solicitation from the University and the Wisconsin Departments of Natural Resources; Agriculture, Trade and Consumer Protection; Industry, Labor and Human Relations; and advice of the Wisconsin Groundwater Research Advisory Council and the with the concurrence of the Wisconsin Groundwater Coordinating Council.*

## ABSTRACT

There has been an increasing interest in the effects of changes in the composition of the pore fluids on the sorptive process. This growing body of literature shows that the effective solubility of organic compounds is changed by the presence of other organic molecules. The presence of naturally occurring organic compounds has been shown to increase the solubility of a variety of organic pollutants including PCBs, PAHs, DDT, and others.

The effects on sorption of a particular organic pollutant caused by the presence of other organic chemical compounds are two-fold. The first effect is a decrease in sorption caused by the formation of aqueous phase complexes. The second effect increases sorption due to an altering of the sediment surfaces by the organic solvents. It is usually assumed that this surface alteration is caused by a partial organic coating of the sediment surfaces in some manner. The relative importance of these two effects on the sorption of a specific pollutant in the presence of an organic-rich model landfill leachate was investigated.

A series of batch sorption experiments between pollutant and sediment in solutions ranging from pure water to 100% leachate were performed to determine the relative importance of these two factors. Subsequent series of batch experiments were performed at differing sediment:water ratios. The pollutants of interest (phenanthrene and naphthalene), the composition of the leachate, and the sediment were chosen to reflect actual conditions in Wisconsin. The presence of low levels of leachate does not affect the sorption of phenanthrene or naphthalene to the sediment.

These data provide important information on the adsorptive behavior of a highly hydrophobic compound near the leading edge of a leachate plume. In addition, these data provide information on the behavior of hydrophobic compounds in river or estuarine systems with low sediment/water ratios.

## CONTENTS

Abstract .....	ii
Figures .....	iv
Tables .....	iv
Introduction .....	1
Materials and Methods .....	3
Results and Discussion .....	5
Conclusions .....	13
References .....	15

## FIGURES

<u>Number</u>		<u>Page</u>
1	Relationship between amount of soil-derived dissolved organic carbon in the aqueous phase and the concentration of soil present .....	6
2	Sorption coefficients of naphthalene versus model leachate concentration plotted as differing sediment concentrations .....	7
3	Sorption coefficients of maphthalene versus soil concentration plotted at a constant concentration of 250 ppm .....	8
4	Sorption coefficients of phenanthrene versus soil concentration plotted at a constant leachate concentration of 250 ppm .....	9
5	Pollutant compartments and distribution coefficients used in the computer model .....	10

## TABLE

1	Best fit values for partition coefficients as defined in Figure 5 .....	10
---	---	----

## INTRODUCTION

While there is often a firm understanding of the toxicological, biochemical, and hydrogeological behavior of individual compounds there is little knowledge of how these compounds behave in the presence of others. There is a critical need to access the potential behavior and effects of complex mixtures that may be leached from waste sites and transported to man through groundwater (Abriola, 1987).

There has been an increasing interest in the effects of changes in the composition of the pore fluids on the sorption process (Kirkner et al., 1984). It has been shown that the simultaneous uptake of binary mixtures of non-ionic compounds such as chlorinated benzenes indicate competitive effects (Chiou and Porter, 1983) and that the adsorption of volatile halogenated hydrocarbons such as chloroform and tetrachloroethane can be predicted from ideal adsorbed solution theory (Crittenden et al., 1985). Nkedi-Kizza et al. (1985, 1987) have examined the effects of organic cosolvents on the adsorption of herbicides and polyaromatic hydrocarbons such as anthracene to soils as part of the development of a solvophobic theory to describe sorption and transport of hydrophobic compounds in mixed solvents. Rao et al. (1990) studied sorption of hydrophobic organic chemicals in the presence of mixed solvents, both miscible and immiscible.

This growing body of literature shows that the effective solubility of organic compounds is changed by the presence of other organic molecules. The presence of naturally occurring organic compounds has been shown to increase the solubility of polychlorinated biphenyls (PCBs), polyaromatic hydrocarbons (PAHs), DDT, and pyrene (Hasset and Milicic, 1985; Carter and Suffett, 1982; McCarthy and Jimenez, 1985; Kandrum et al., 1984; Gauthier et al., 1987). Pinal et al. (1990) studied cosolvency of hydrophobic organic chemicals in the presence of mixed solvents, both miscible and partially miscible, and applied a log-linear cosolvency model to the results.

The effects on sorption of a particular organic pollutant caused by the presence of other organic chemicals (solvents) are two-fold. The first effect is a decrease in sorption caused by the formation of aqueous phase complexes. The second effect increases sorption due to an altering of the sediment surfaces by the organic solvents. It is usually assumed that this surface alteration is caused by a partial organic coating of the sediment surfaces in some manner (Rao et al., 1990). Rao et al. (1990) performed a qualitative experiment using hydrophobic and hydrophilic dyes to see if sediment grains become coated with hydrophobic organics. The relative importance of these two effects on the sorption of a specific pollutant in the presence of an organic-rich landfill leachate was investigated.

The extent of sorption is usually defined in terms of distribution of coefficients ( $K_p$ ). The distribution coefficient between the aqueous and sorbed state for a single pollutant in a water/sediment system is:

$$K_p^{\circ} = \frac{PS}{P} \quad (1)$$

where:

- $K_p^{\circ}$  = distribution coefficient in pure water;
- PS = concentration of pollutant sorbed to the unaltered sediment (concentration pollutant/unit mass sediment); and
- P = concentration of pollutant in the aqueous phase (concentration pollutant/unit volume water).

A more complete description of the sorption of a pollutant in a leachate/sediment system is given by equation (2).

$$K_p = \frac{PS_{DOC} + PS + PS_L}{P_{DOC} + P + P_L} \quad (2)$$

where:

- $PS_{DOC}$  = concentration of pollutant-natural dissolved organic carbon (DOC) complexes sorbed to sediment;
- PS = concentration of pure pollutant sorbed to the sediment;
- $PS_L$  = concentration of pollutant-leachate complexes sorbed to the sediment;
- $P_{DOC}$  = concentration of pollutant-natural DOC complexes in the aqueous phase;
- P = concentration of free pollutant in the aqueous phase; and
- $P_L$  = concentration of pollutant-leachate complexes in the aqueous phase.

It is assumed that hydrophobically driven sorption dominates with these compounds and that sorption to the bare mineral surfaces is minimal. Sorption decreases caused by aqueous phase complexing with leachate is embodied in  $P_L$ . Sorption increases caused by alteration of sediment surfaces by leachate is embodied in  $PS_L$ . Absolute values of either the aqueous phase complexing constants ( $P_L$ ) or the extent of sorption to the leachate-altered portion of the sediment ( $PS_L$ ) cannot be determined.

The relative importance of the factors defined in equation (2) were determined by performing a series of batch-sorption experiments between pollutant and sediment in solutions ranging from 1% to 100% leachate. Experiments at 1% yielded values of  $K_p^{\circ}$  while other experiments yielded  $K_p$  values. Any decrease in  $K_p$  with increasing percent leachate is due to a combination of the opposing effects of aqueous phase complexing ( $P_L$ ) and sediment surface alteration ( $PS_L$ ).

The overall objective of this project was to ascertain the relative importance of aqueous phase complexing versus surface alteration on the sorption of hydrophobic organic pollutants to sediment in the presence of a complex leachate mixture. The pollutant of interest, the composition of the leachate, and the sediment were all chosen to reflect actual conditions in Wisconsin.

## MATERIALS AND METHODS

A data set containing analyses from more than 100 landfill leachates nationwide was used as a data base to fabricate a model leachate. The model leachate contains five of the most commonly found compounds in real leachates. These five represent a wide variety of chemical classes, including acid extractable (phenol and m-cresol), base-neutral extractable (diethylphthalate), and volatile organics (1,1,1-trichloroethane and toluene). All of these compounds are common constituents in Wisconsin landfill leachate. The dissolved organic carbon (DOC) of the leachate was held to 750 mg/liter. This concentration is representative of leachates found in Wisconsin. In order to avoid problems with leachate components dissolving in water, component concentrations were kept <50% of their reported solubility. In order to verify the results obtained in the model leachate, the experiments were repeated in a real leachate collected from the Parkview landfill located in Milwaukee County. The DOC content was adjusted by dilution with de-ionized water. The soil used was typical of the clay-rich, organic-poor subsoil found in southeastern Wisconsin. The soil was classified as Kewaunee silt loam.

The pollutants used were two commonly found polycyclic aromatic hydrocarbons (PAHs), phenanthrene and naphthalene. Phenanthrene exhibits a rather high sorptive capability as reflected in a high octanol-water partition coefficient ( $\text{Log } K_{\text{OC}}=4.45$ ) and low water solubility ( $S=1 \text{ mg/L}$ ) (Verschueren, 1983). Naphthalene is a less sorptive compound ( $\text{log } K_{\text{OC}}=3.45$  and  $S=32 \text{ mg/L}$ ) (Verschueren, 1983). Both compounds used in these experiments were radio-labeled ( $^{14}\text{C}$ ). Radio-labeled compounds were obtained from Sigma Scientific. All other compounds were reagent grade.

The soil was characterized for soil pH, total organic carbon (TOC), and cation exchange capacity (CEC). Soil pH was measured in a 1:1 (by weight) soil water mixture. The TOC was measured on a Carlo Erba C-H-N analyzer and CEC was determined by  $\text{Na}^+$  saturation of the exchange sites following the procedure of Polemio and Rhodes (1977).

Batch adsorption experiments were carried out at sediment:water ratios of 40, 20, and 10 g/L. Experiments with differing leachate concentrations were performed at each sediment:water ratio. Leachate concentrations varied from 100% leachate ( $\text{DOC} = 750 \text{ mg/L}$ ) to 1.5% leachate ( $\text{DOC} = 11 \text{ mg/L}$ ). Lower leachate concentrations could not be achieved because the pollutant was dissolved in toluene, thus, the addition of pollutant necessitated the addition of DOC. All experiments were equilibrated on a wrist action shaker for a minimum of 48 hours.

Radio-labeled pollutant was measured on a Hewlett Packard Tri-Carb 1500 liquid scintillation counter. A xylene-based fluor was used to extract NAC from the sediment and water phases. Phase separation was performed by centrifugation. Partition coefficients were determined by measuring NAC concentrations in both phases. Resulting mass balances were typically greater than 90%. All experiments were performed in triplicate and results were averaged.



## RESULTS AND DISCUSSION

The soil sample had a pH of 7.4, TOC of 0.39%, and CEC of 21 meq/100 g. These values are representative of subsoils encountered in southeastern Wisconsin. Series of adsorption experiments at different leachate concentrations and at different sediment/water ratios were performed. In order to quantify the amount of dissolved organic carbon (DOC) present in the water due to the presence of soil, ancillary experiments were performed using samples of successively increasing sediment/water ratios. The amount of soil-derived DOC found in the water was a log linear function of sediment concentration (Figure 1). The equation for the relation shown in Figure 1 is:

$$\text{DOC} = A s^b \quad (3)$$

where:

DOC = concentration of soil-derived organic carbon (g carbon/L);  
S = concentration of soil (g/mL); and  
A, b = constants.

Best fit values for A and b are  $5.1E-5$  and  $0.572$ , respectively. These values of A and b were used to calculate the amount of DOC present in the aqueous phase for each sediment concentration used in the primary sorption experiments. Mass balance constraints were used to calculate the amount of organic carbon left on the soil.

Figure 2 shows the  $K_p$  values for naphthalene versus leachate concentration at various soil concentrations. Notable in this data is the complete lack of sorption dependence on leachate concentration. Also notable is the strong dependence of sorption on sediment concentration. A plot of naphthalene  $K_p$  versus sediment concentration for a leachate concentration is shown in Figure 3. Phenanthrene behaves in a similar manner (Figure 4). Phenanthrene is the more hydrophobic of the two compounds and this is reflected in the higher absolute  $K_p$  values for phenanthrene.

Figures 3 and 4 also demonstrate that model leachate and real leachate from the Parkview landfill behave in essentially the same manner. The  $K_p$  value for a sediment concentration of 0.04 in Figure 4 is anomalous and unexplained. The trend at other leachate concentrations parallels that of the model leachate.

A change in  $K_p$  values as sediment concentration is varied, referred to as the sorbent concentration effect, is well documented and several models have been proposed to explain this effect (e.g., Geschwind and Wu, 1985; Voice and Weber, 1985). Both of these models invoke that the pollutant exists in two states in the aqueous phase and one in the sediment phase to explain their data. In all cases reported in the literature the sorbent concentration effect increases the  $K_p$  as sediment concentrations decrease.

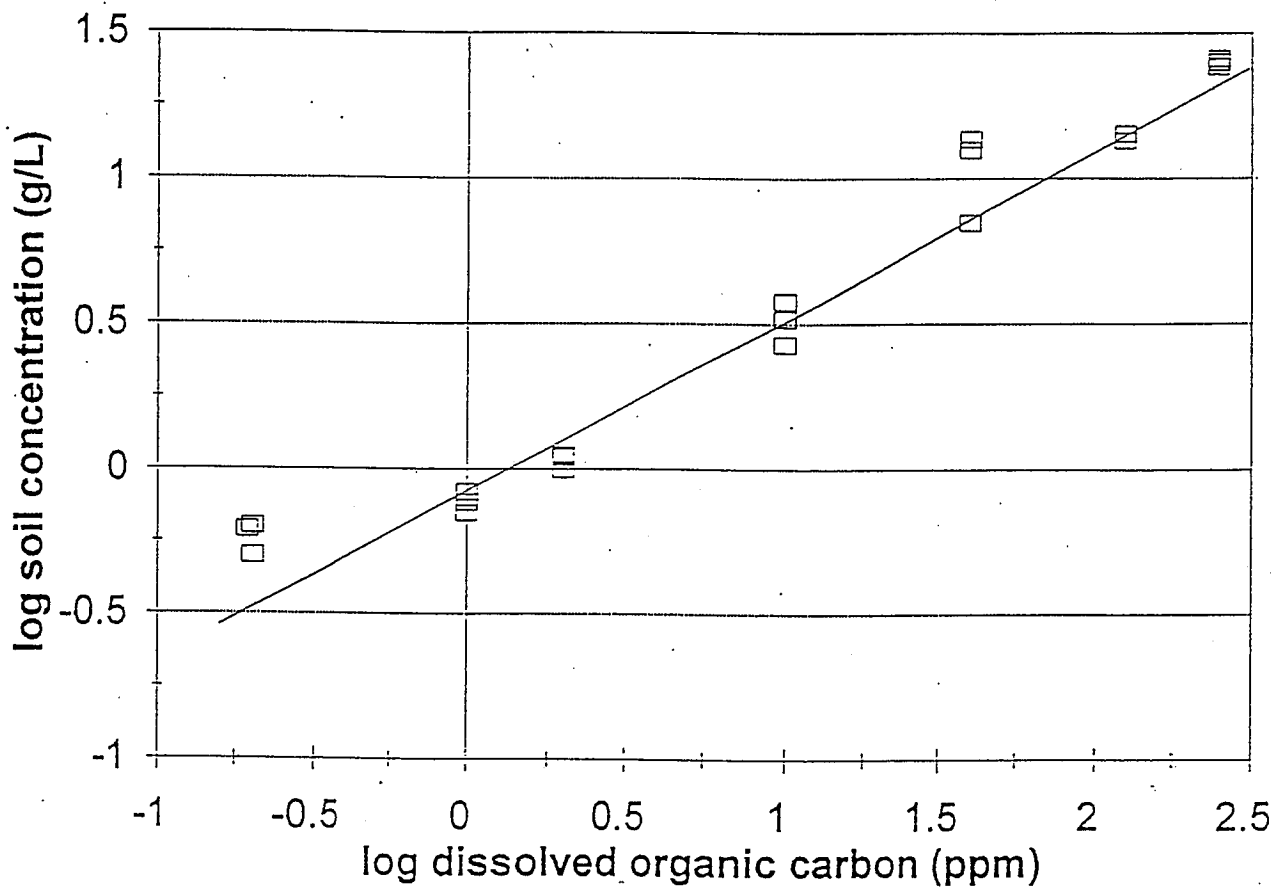
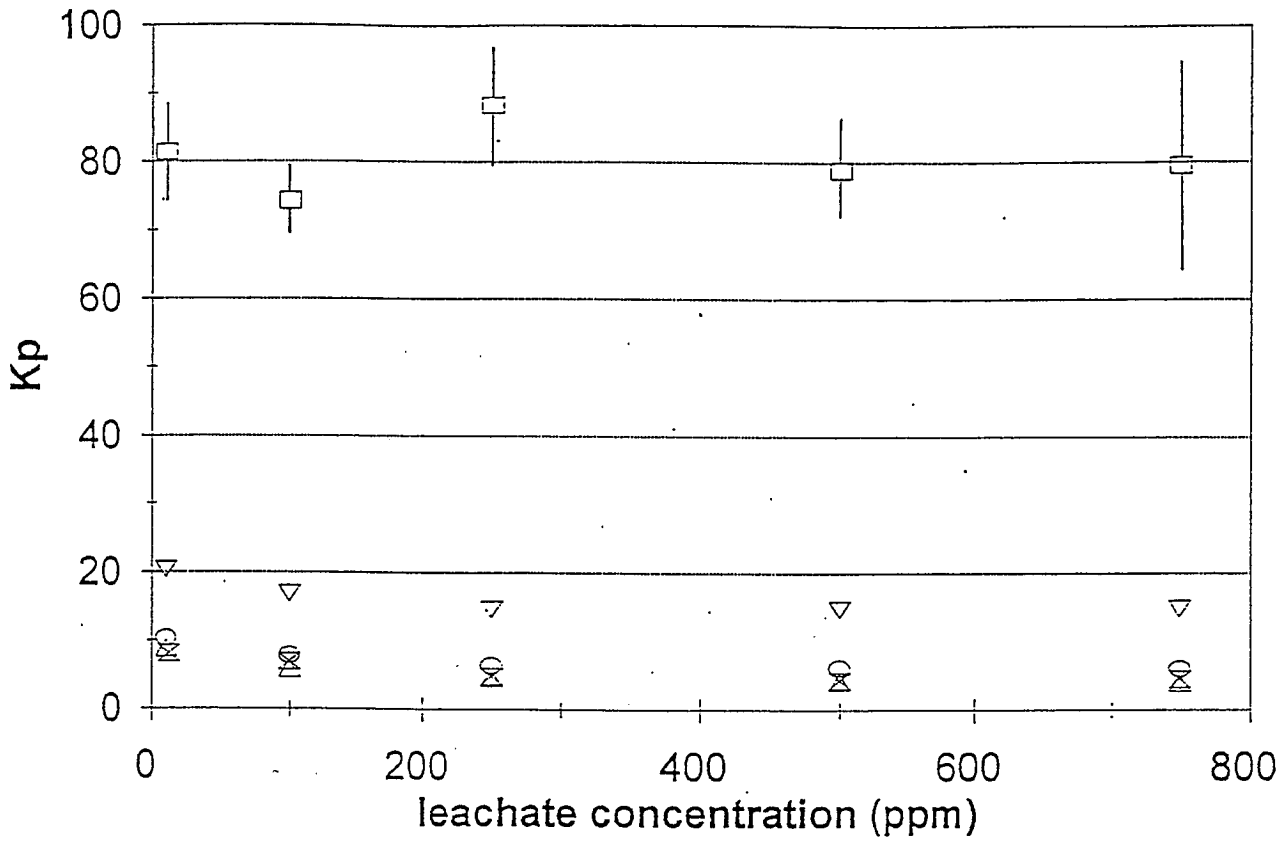

Figure 1. Relationship between amount of soil-derived organic carbon in the aqueous phase and the concentration of soil present.



□ 2E-4 g/mL ▽ 2E-3 g/mL ○ 1E-2 g/mL △ 4E-2 g/mL ⊗ 0.25 g/mL

Figure 2. Sorption coefficients of naphthalene vs. model leachate concentration plotted as differing sediment concentrations. Error of  $\pm$  one standard deviation is within the size of the symbol, except where shown by error bars.

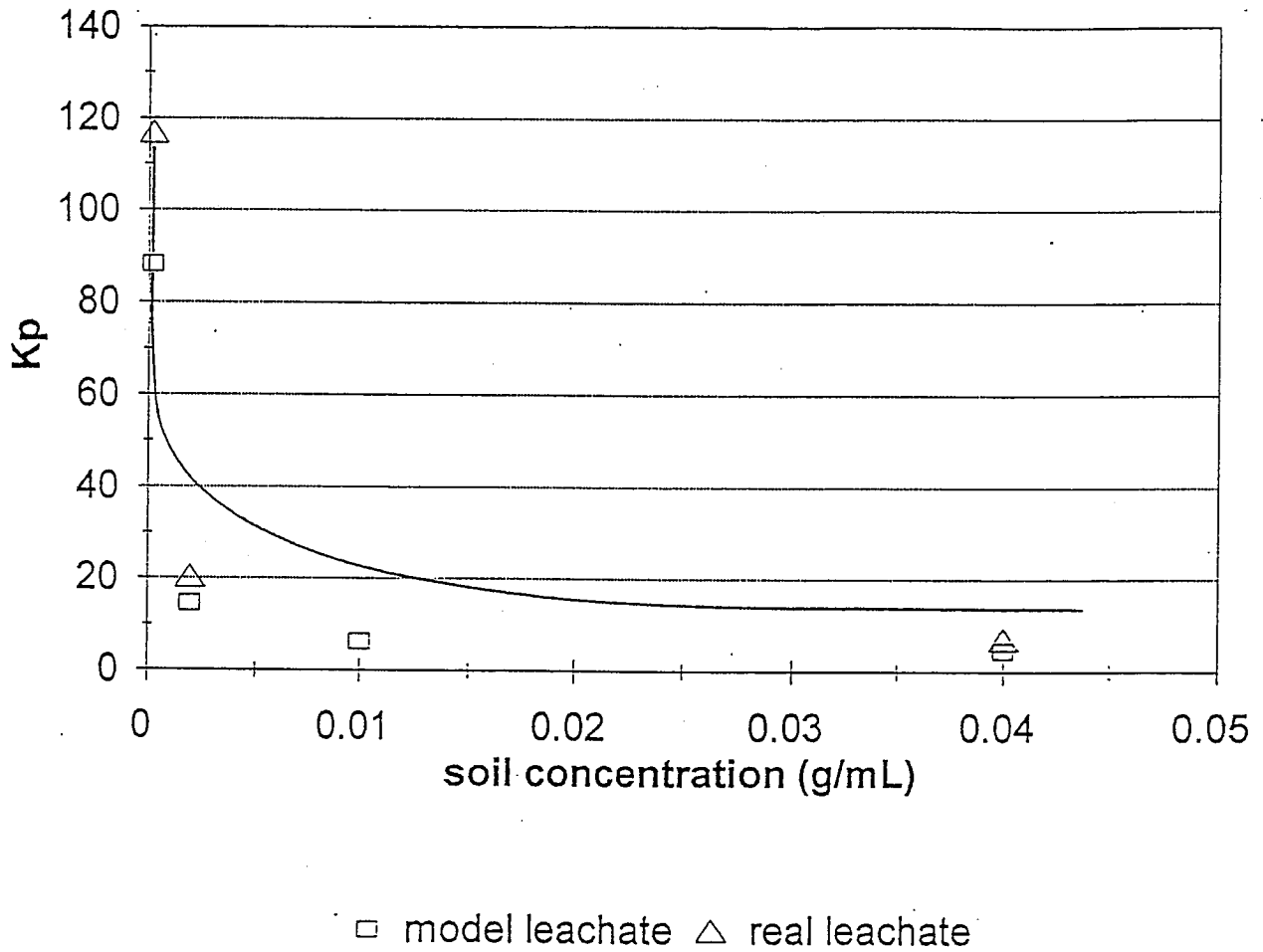

Figure 3. Sorption coefficients of naphthalene vs. soil concentration plotted at a constant leachate concentration of 250 ppm. Squares represent model leachate; triangles represent real leachate. The solid line is the modeled best fit.

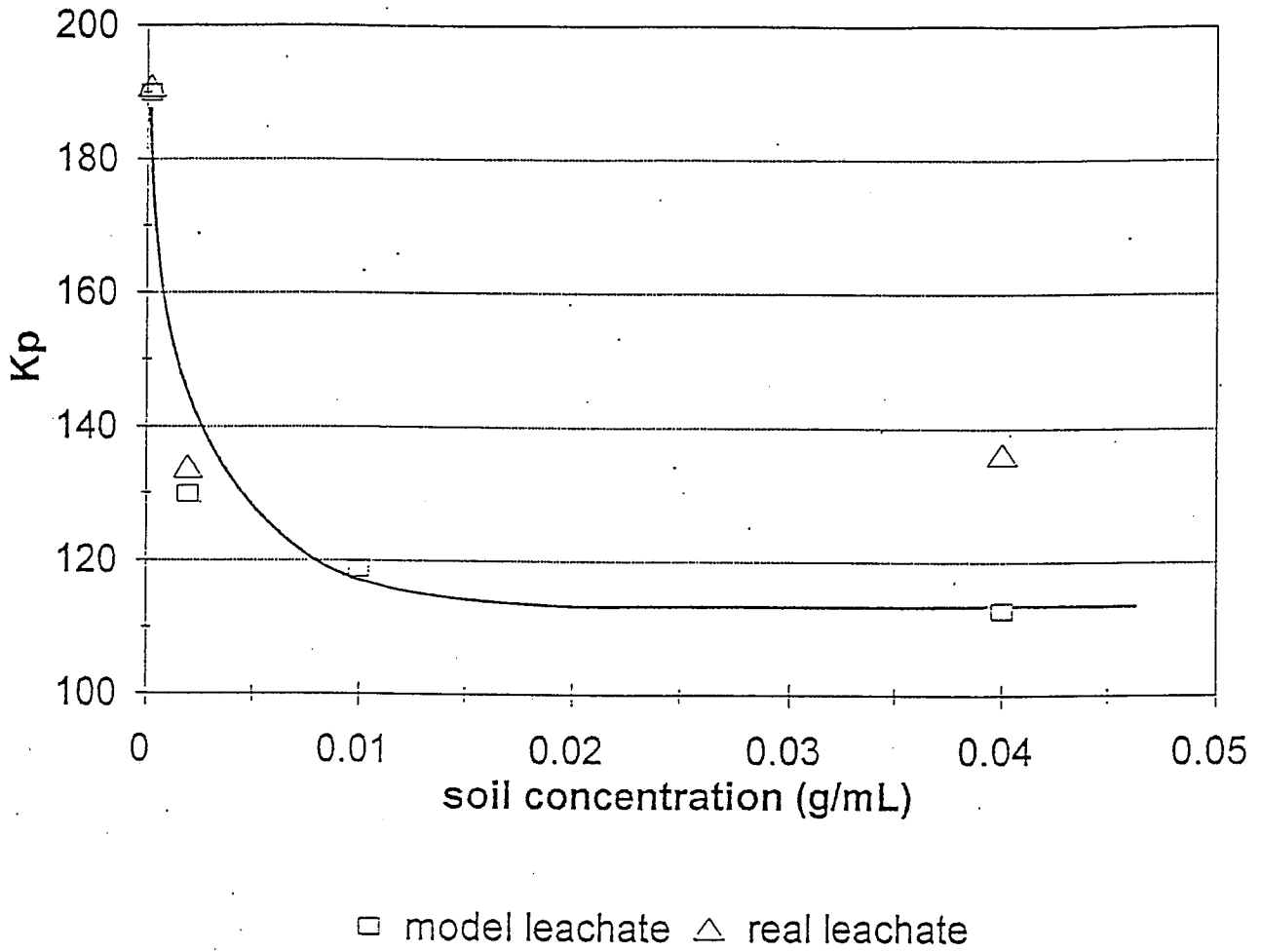

Figure 4. Sorption coefficients of phenanthrene vs. soil concentration plotted at a constant leachate concentration of 250 ppm. Squares represent model leachate; triangles represent real leachate. The solid line is the modeled best fit.

In order to assess the relative importance of each of the six compartments in which the pollutant can reside [see Eq. (2)] a simple computer model was written. This program partitions pollutants into each compartment depending on mass balance constraints and user-defined partition coefficient. The amount of DOC present is calculated by Eq. (3). The partition coefficients are defined in Figure 5. Table 1 lists the best fit values for these coefficients. The solid line seen in Figures 3 and 4 represents the modeled values.

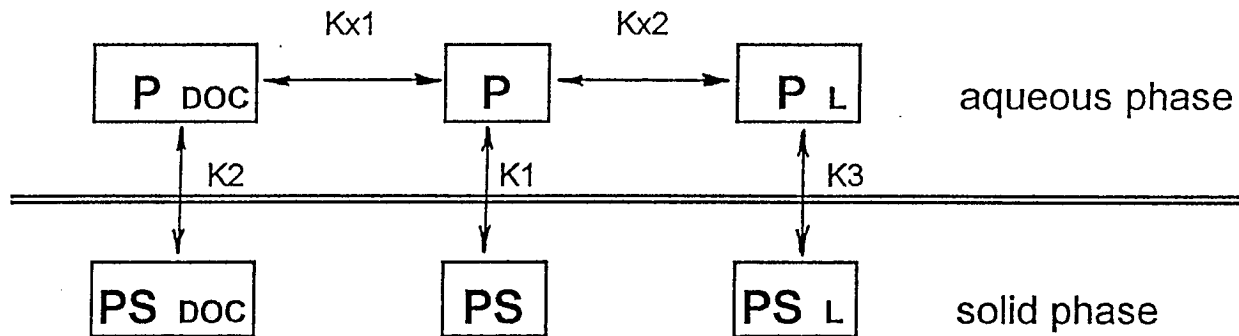

Figure 5. Pollutant compartments and distribution coefficients used in the computer model.

Table 1. Best fit values for partition coefficients as defined in Figure 5.

Pollutant	Aqueous Complexing Coefficients		Sorptive Coefficients		
	$K_{x1}$	$K_{x2}$	$K_1$	$K_2$	$K_3$
Naphthalene	2.0E7	0	1.4E5	1.2E3	(0)
Phenanthrene	1.4E7	0	4.4E5	2.0E4	(0)

The influence of leachate on the aqueous speciation of pollutant is negligible, as is reflected in the value of zero for  $K_{x2}$ . Because there is essentially no  $P_L$  complexes in solution, the model is insensitive to  $K_3$ . By contrast, the aqueous complexing between DOC and pollutant is large ( $K_{x1}$ ) and the subsequent sorption of these complexes is significant ( $K_2$ ). This seems reasonable in light of the fact that phenanthrene and naphthalene are much larger molecules than any of the leachate compounds and thus obtain little hydrophobic advantage by forming  $P_L$  complexes. By contrast, DOC molecules are typically larger, sometimes reaching molecular weights of several thousand, therefore,  $P_{DOC}$  complexes are highly favored. Sorption of the pure pollutant ( $K_1$ ) is roughly 100x greater than the sorption of pollutant-DOC complexes.

The highly non-linear nature of the sorbent concentration effect is due to the non-linear nature of Eq. (3). At high sediment concentrations, the percent increase in DOC is larger than the

percent decrease in soil organic carbon and this drives the overall  $K_p$  down (i.e., sorption efficiency decreases). The sorbent concentration effect only becomes evident at soil concentrations  $<10$  mg/mL (Figures 3 and 4). Therefore, this is not a problem for groundwater systems in which soil concentrations are much higher. Surface waters have sediment concentrations  $<10$  mg/mL and will be susceptible to this sorbent concentration effect. The direct extrapolation of this data to surface water systems must be done with care because suspended material in surface water bodies contains an abundance of living organisms and is not directly analogous to the sediment used in this study.

## CONCLUSIONS

This study demonstrates that for hydrophobic molecules, such as phenanthrene and naphthalene, the presence of landfill leachate does little to change the sorptive properties of the system. This is an important finding in that widely published  $K_{oc}$  values for hydrophobic compounds can be confidently used when modeling their behavior in the presence of landfill leachate.

Although the sorbent concentration effect is marked at low sediment concentrations, it is not a problem for typical groundwater systems. A simple computer model was used to fit the data and it shows that the sorption of pure pollutant to the sediment is important. In addition, the aqueous phase complexing between pollutant and DOC and the subsequent sorption of this complex to the sediment is also important.



## REFERENCES

- Abriola, L.M. 1987 Modeling contaminant transport in the subsurface: an interdisciplinary challenge. In: Contributions in Hydrology. American Geophysical Union, pp. 125-134.
- Carter, C.W. and I.H. Suffet. 1982. Binding of DDT to dissolved humic materials. *Environ. Sci. Technol.* 16: 735-740.
- Chiou, C.T., and P.E. Porter. 1983. Partition equilibria of nonionic organic compounds between soil organic matter and water. *Environ. Sci. Technol.* 17: 227-231.
- Crittenden, J.C., P. Luft, D.W. Hand, J.L. Orvitz, S.W. Loper and M. Arl. 1985. Prediction of multicomponent adsorption equilibria using ideal adsorbed solution theory. *Environ. Sci. Technol.* 19: 1037-1043.
- Gauthier, T.D., W.R. Seitz and C.L. Grant. 1987. Effects of structural and compositional variations of dissolved humic materials on pyrene  $K_{oc}$  values. *Environ. Sci. Technol.* 21: 243-247.
- Geschwind, P. and S. Wu. 1985. On the constancy of sediment-water partition coefficients of hydrophobic organic pollutants. *Environ. Sci. Technol.* 19: 90-96.
- Hassett, J.P. and E. Milicic. 1985. Determination of equilibrium and rate constants for binding of a polychlorinated biphenyl congener by dissolved humic substances. *Environ. Sci. Technol.* 19: 636-643.
- Kirkner, D.J., T.L. Thesis and A.A. Jennings. 1984. Multicomponent solute transport with sorption and soluble complexation. *Adv. Water Resour.* 7: 120-125.
- Kandrum P.R., S.R. Nihart, B.J. Eadie and W.S. Gardner. 1984. Reserve-phase separation method for determining pollutant binding to Aldrich humic acid and dissolved organic carbon of natural waters. *Environ. Sci. Technol.* 18: 187-192.
- Lyman, W., W. Rechl and D. Rosenblatt. 1982. *Handbook of Chemical Property Estimation Methods*. McGraw-Hill, New York, 547 pp.
- McCarthy, J.F. and B.D. Jimenez. 1985. Interactions between PAH's and dissolved humic material: binding and dissociation. *Environ. Sci. Technol.* 19: 1076-1081.
- Nkedi-Kizza, P., P.S.C. Rao and A.G. Hornsby. 1985. Ion-exchange and diffusive mass transfer during miscible displacement through an aggregated osixol. *Soil Sci. Soc. Am. J.* 46: 471-475.

- Nkedi-Kizza, P., P.S.C. Rao and A.G. Hornsby. 1987. Influence of organic cosolvents on sorption of hydrophobic organic chemicals by soils. *Environ. Sci. Technol.* 19: 975-979.
- Pinal, R., P.S.C. Rao, L. Lee, P. Cline and S. Yalkowsky. 1990. Cosolvency of partially miscible organic solvents on the solubility of hydrophobic organic chemicals. *Environ. Sci. Technol.* 24: 639-647.
- Polemio, M. and J.D. Rhodes. 1977. Determining the cation exchange capacity: a new procedure for calcareous and gypsiferous soils. *Soil Sci. Soc. Am. J.* 41: 524-528.
- Rao, P.S.C., L. Lee and R. Pinal. 1990. Cosolvency and sorption of hydrophobic organic chemicals. *Environ. Sci. Technol.* 24: 647-654
- Verschueren, K. 1983. *Handbook of Environmental Data on Organic Chemicals*, 2nd edition. Van Nostrand, Reinhold, publ. 1217 pp.
- Voice, T. and W. Weber. 1985. Sorbent concentration effects in liquid/solid partitioning. *Environ. Sci. Technol.* 19: 789-796.